

Legend:

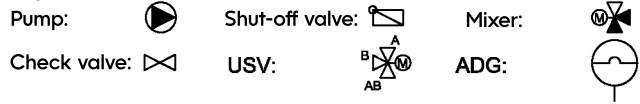

Note:

- Heat exchanger surface area in the boiler should be approx. 0.4 m²/kW
- Provide at least 300 l volume for domestic hot water
- Provide at least 300 l buffer volume for heating
- Do not use automatic air vents or safety valves in the building (safety valve is located in the unit)
- Observe the dew point during active cooling

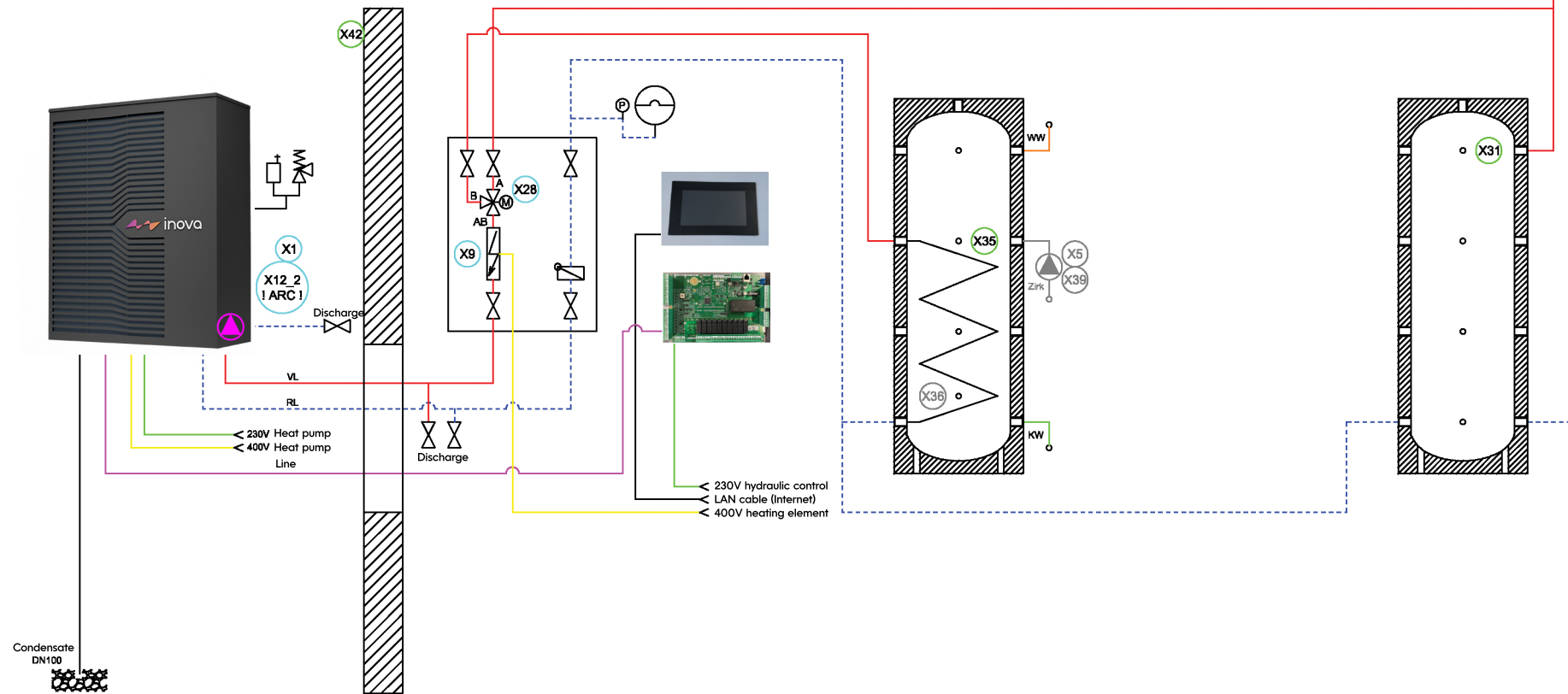
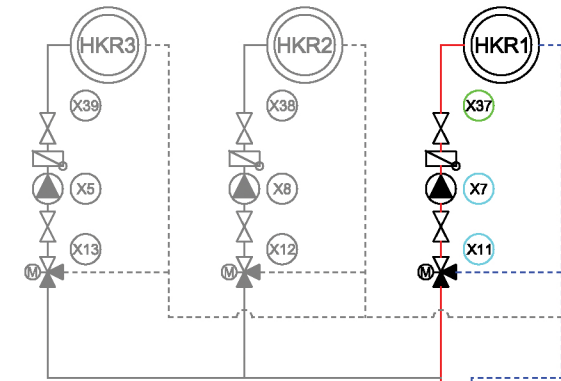

No guarantee of accuracy. This drawing represents a schematic diagram and may differ from actual practice. Reproduction is permitted only with written consent.

Designation:
Dual storage solution with boiler and buffer tank

Date:	24.02.2026
Name:	Inova